

VAL-MS 350VF - Type 2 surge arrester



2856582

<https://www.phoenixcontact.com/gb/products/2856582>

Please be informed that the data shown in this PDF document is generated from our online catalog. Please find the complete data in the user documentation. Our general terms of use for downloads are valid.

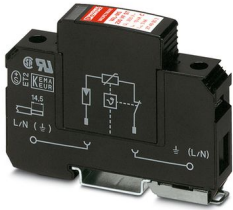

Surge voltage arrester consisting of base element with protective plug with a connection in series with a varistor and a gas-filled spark gap, for mounting on NS 35/7.5, nominal voltage: 230 V AC, 1-channel

Your advantages

- Quality proven millions of times over in the widest range of applications
- Rapid installation with bridges, thanks to industry-standard overall width of 1 HP
- Easy testing and insulation measurement, thanks to pluggable protection modules
- Suitable for use in insulation-monitored systems due to combination of varistor and gas discharge tube free of leakage current
- Can be used in applications with increased insulation strength, e.g., railway technology

Commercial data

Item number	2856582
Packing unit	1 pc
Minimum order quantity	1 pc
Sales key	CL1321
Product key	CL1321
Catalog page	Page 62 (C-4-2019)
GTIN	4017918876845
Weight per piece (including packing)	130.5 g
Weight per piece (excluding packing)	110.03 g
Customs tariff number	85363030
Country of origin	DE

VAL-MS 350VF - Type 2 surge arrester



2856582

<https://www.phoenixcontact.com/gb/products/2856582>

Technical data

Notes

General

Note	Usable in all low-voltage systems between L-N or L-PEN. Only usable in IT Systems between L-PE, if the exposed-conductive-parts (bodies) of the equipment of the low-voltage installation is connected to the earthing arrangement of the transformer substation. (interconnected earthing arrangement of the HV-transformer substation with the bodies of the LV-installation. $R_E = R_A$ accordance to IEC 60364-4-442 / VDE 0100-442 Fig. 44D / Example a)
------	---

Product properties

IEC test classification	II T2
EN type	T2
IEC power supply system	TN TT IT
Type	DIN rail module, two-section, divisible
Product type	Surge arrester
Product family	VALVETRAB MS
Number of positions	1
Surge protection fault message	optical

Insulation characteristics

Overvoltage category	III
Pollution degree	2

Electrical properties

Nominal frequency f_N	50 Hz (60 Hz)
-------------------------	---------------

Connection data

Connection method	Screw connection
Screw thread	M5
Tightening torque	3 Nm (1.5 mm ² ... 16 mm ²) 4.5 Nm (25 mm ² ... 35 mm ²)
Stripping length	16 mm
Conductor cross section flexible	1.5 mm ² ... 25 mm ²
Conductor cross section rigid	1.5 mm ² ... 35 mm ²
Conductor cross section AWG	15 ... 2
Connection method	Fork-type cable lug
Conductor cross section flexible	1.5 mm ² ... 16 mm ²

Dimensions

VAL-MS 350VF - Type 2 surge arrester



2856582

<https://www.phoenixcontact.com/gb/products/2856582>

Dimensional drawing	
Width	17.6 mm
Height	89.8 mm
Depth	65.7 mm (incl. DIN rail 7.5 mm)
Horizontal pitch	1 Div.

Material specifications

Color	black (RAL 9005)
Flammability rating according to UL 94	V-0
CTI value of material	600
Insulating material	PA 6.6/PBT
Material group	I
Housing material	PA 6.6 PBT

Protective circuit

Mode of protection	L-N
	L-PE
	L-PEN
Direction of action	1L-N/PE
Nominal voltage U_N	240/415 V AC (TN)
	240/415 V AC (TT)
	230 V AC (IT)
Nominal frequency f_N	50 Hz (60 Hz)
Maximum continuous voltage U_C	350 V AC
Rated load current I_L	80 A
Residual current I_{PE}	$\leq 5 \mu\text{A}$
Standby power consumption P_C	$\leq 2.00 \text{ mVA}$
Nominal discharge current I_n (8/20) μs	10 kA
Maximum discharge current I_{max} (8/20) μs	20 kA
Short-circuit current rating I_{SCCR}	25 kA
Voltage protection level U_p	$\leq 1.5 \text{ kV}$
Residual voltage U_{res}	$\leq 1.2 \text{ kV}$ (at I_n)
	$\leq 1.2 \text{ kV}$ (at 10 kA)
	$\leq 1.1 \text{ kV}$ (at 5 kA)
Front of wave sparkover voltage at 6 kV (1.2/50) μs	$\leq 1.5 \text{ kV}$
TOV behavior at U_T	415 V AC (5 s / withstand mode)
	440 V AC (120 min / withstand mode)
Response time t_A	$\leq 100 \text{ ns}$
Max. backup fuse with V-type through wiring	80 A (gG)

VAL-MS 350VF - Type 2 surge arrester



2856582

<https://www.phoenixcontact.com/gb/products/2856582>

Max. backup fuse with branch wiring	125 A (gG)
-------------------------------------	------------

Additional technical data

Impulse discharge current (10/350) μ s, charge	0.25 As
Impulse discharge current (10/350) μ s, specific energy	62.5 J/ Ω
Impulse discharge current (10/350) μ s, peak value I_{imp}	500 A

Environmental and real-life conditions

Ambient conditions

Degree of protection	IP20 (only when all terminal points are used)
Ambient temperature (operation)	-40 °C ... 80 °C
Ambient temperature (storage/transport)	-40 °C ... 80 °C
Altitude	\leq 2000 m (amsl)
Permissible humidity (operation)	5 % ... 95 %
Shock (operation)	25g (Half-sine / 11 ms / 3x \pm X, \pm Y, \pm Z)
Vibration (operation)	5g (10 ... 500 Hz / 2.5 h / X, Y, Z)

Approvals

UL specifications

Maximum continuous operating voltage MCOV (L-N)	350 V AC
Nominal discharge current I_n (L-N)	10 kA
Mode of protection	L-N
Nominal voltage	240 V AC
Power distribution system	Single phase
Nominal frequency	50/60 Hz
Measured limiting voltage MLV (L-N)	2420 V
SPD Type	4CA

UL connection data

Tightening torque	30 lb _F -in.
Conductor cross section AWG	14 ... 2

Standards and regulations

Standards/specifications	IEC 61643-11
Note	2011
Standards/specifications	EN 61643-11
Note	2012

Mounting

Mounting type	DIN rail: 35 mm
---------------	-----------------

VAL-MS 350VF - Type 2 surge arrester

2856582

<https://www.phoenixcontact.com/gb/products/2856582>

Drawings

Dimensional drawing

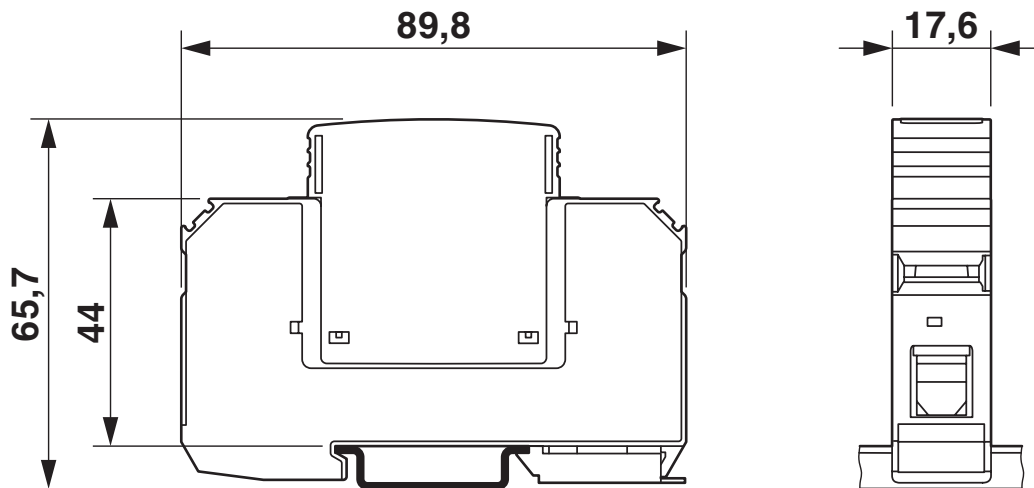

Circuit diagram

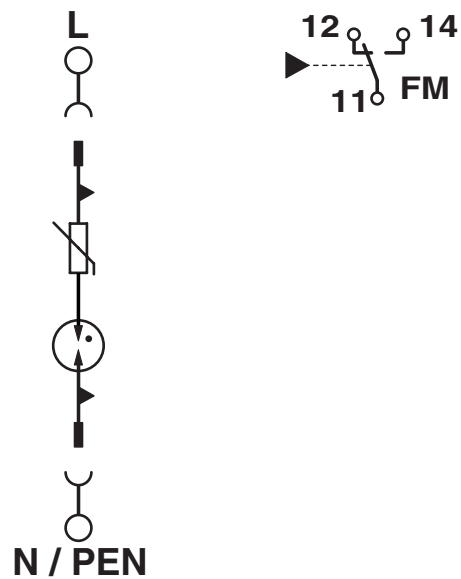

VAL-MS 350VF - Type 2 surge arrester



2856582

<https://www.phoenixcontact.com/gb/products/2856582>

Approvals

To download certificates, visit the product detail page: <https://www.phoenixcontact.com/gb/products/2856582>



cUL Recognized

Approval ID: FILE E 330181



UL Recognized

Approval ID: FILE E 330181



IECEE CB Scheme

Approval ID: AT 2905/M1



EAC

Approval ID: EAC-Zulassung

CCA

Approval ID: NTR-AT 1947-A



KEMA-KEUR

Approval ID: 71-113273 REV.1



EAC

Approval ID: RU C-DE.*09.B.00169



CSA

Approval ID: 13631



ÖVE

Approval ID: 18583-001-17

UAE-RoHS

Approval ID: 22-09-51251

cULus Recognized

VAL-MS 350VF - Type 2 surge arrester



2856582

<https://www.phoenixcontact.com/gb/products/2856582>

Classifications

ECLASS

ECLASS-11.0	27130805
ECLASS-13.0	27171202

ETIM

ETIM 9.0	EC000941
----------	----------

UNSPSC

UNSPSC 21.0	39121600
-------------	----------

VAL-MS 350VF - Type 2 surge arrester



2856582

<https://www.phoenixcontact.com/gb/products/2856582>

Environmental product compliance

China RoHS	Environmentally friendly use period: unlimited = EFUP-e
	No hazardous substances above threshold values

VAL-MS 350VF - Type 2 surge arrester

2856582

<https://www.phoenixcontact.com/gb/products/2856582>

Accessories

MPB 18/1- 2 - Wiring bridge

2809209

<https://www.phoenixcontact.com/gb/products/2809209>



Wiring bridge for modules with connecting pitch 17.5 mm, 1-phase, 2-pos.

MPB 18/1- 3 - Wiring bridge

2809212

<https://www.phoenixcontact.com/gb/products/2809212>



Wiring bridge for modules with connecting pitch 17.5 mm, 1-phase, 3-pos.

VAL-MS 350VF - Type 2 surge arrester

2856582

<https://www.phoenixcontact.com/gb/products/2856582>

MPB 18/1- 4 - Wiring bridge

2809225

<https://www.phoenixcontact.com/gb/products/2809225>

Wiring bridge for modules with connecting pitch 17.5 mm, 1-phase, 4-pos.



MPB 18/1- 6 - Wiring bridge

2748564

<https://www.phoenixcontact.com/gb/products/2748564>

Wiring bridge for modules with connecting pitch 17.5 mm, 1-phase, 6-pos.



VAL-MS 350VF - Type 2 surge arrester

2856582

<https://www.phoenixcontact.com/gb/products/2856582>

MPB 18/1- 7 BU - Wiring bridge

2856278

<https://www.phoenixcontact.com/gb/products/2856278>



Wiring bridge for modules with connecting pitch 17.5 mm, 1-phase, 7-pos., color: Blue

MPB 18/1- 8 BU - Wiring bridge

2858470

<https://www.phoenixcontact.com/gb/products/2858470>

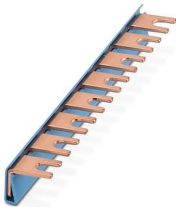

Wiring bridge for modules with connecting pitch 17.5 mm, 1-phase, 8-pos., color: Blue

VAL-MS 350VF - Type 2 surge arrester

2856582

<https://www.phoenixcontact.com/gb/products/2856582>

MPB 18/1- 8 - Wiring bridge

2748577

<https://www.phoenixcontact.com/gb/products/2748577>



Wiring bridge for modules with connecting pitch 17.5 mm, 1-phase, 8-pos.

MPB 18/1- 9 - Wiring bridge

2748580

<https://www.phoenixcontact.com/gb/products/2748580>



Wiring bridge for modules with connecting pitch 17.5 mm, 1-phase, 9-pos.

VAL-MS 350VF - Type 2 surge arrester

2856582

<https://www.phoenixcontact.com/gb/products/2856582>

MPB 18/1-12 - Wiring bridge

2748593

<https://www.phoenixcontact.com/gb/products/2748593>



Wiring bridge for modules with connecting pitch 17.5 mm, 1-phase, 12-pos.

MPB 18/1-57 - Wiring bridge

2809238

<https://www.phoenixcontact.com/gb/products/2809238>



Wiring bridge for modules with connecting pitch 17.5 mm, 1-phase, 57-pos.

VAL-MS 350VF - Type 2 surge arrester

2856582

<https://www.phoenixcontact.com/gb/products/2856582>



MPB 18/3- 6 - Wiring bridge

2809241

<https://www.phoenixcontact.com/gb/products/2809241>

Wiring bridge for modules with connecting pitch 17.5 mm, 3-phase, 6-pos.

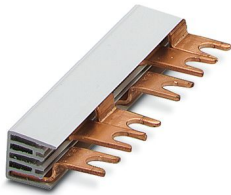

MPB 18/4- 8 - Wiring bridge

2809283

<https://www.phoenixcontact.com/gb/products/2809283>

Wiring bridge for modules with connecting pitch 17.5 mm, 4-phase, 8-pos.



VAL-MS 350VF - Type 2 surge arrester

2856582

<https://www.phoenixcontact.com/gb/products/2856582>

ZBN 18,LGS:ERDE - Marker for terminal blocks

2749589

<https://www.phoenixcontact.com/gb/products/2749589>



Marker for terminal blocks, Strip, white, labeled, horizontal: Grounding symbol, mounting type: snapped, for terminal block width: 18 mm, lettering field size: 18 x 5 mm, Number of individual labels: 5

ZBN 18,LGS:L1-N,ERDE - Marker for terminal blocks

2749576

<https://www.phoenixcontact.com/gb/products/2749576>

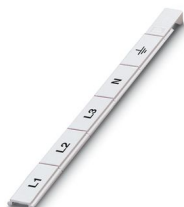

Marker for terminal blocks, Strip, white, labeled, horizontal: L1, L2, L3, N, GND, mounting type: snapped, for terminal block width: 18 mm, lettering field size: 18 x 5 mm, Number of individual labels: 5

VAL-MS 350VF - Type 2 surge arrester

2856582

<https://www.phoenixcontact.com/gb/products/2856582>



ZBN 18:UNBEDRUCKT - Zack marker strip

2809128

<https://www.phoenixcontact.com/gb/products/2809128>



Zack marker strip, Strip, white, unlabeled, can be labeled with: CMS-P1-PLOTTER, PLOTMARK, mounting type: snapped, for terminal block width: 18 mm, lettering field size: 18 x 5 mm, Number of individual labels: 5

DK-BIC-35 - Feed-through terminal block

2749880

<https://www.phoenixcontact.com/gb/products/2749880>



Feed-through terminal block for VAL and FLT applications

VAL-MS 350VF - Type 2 surge arrester

2856582

<https://www.phoenixcontact.com/gb/products/2856582>



VAL-MS 350 VF ST - Type 2 surge protection plug

2856595

<https://www.phoenixcontact.com/gb/products/2856595>



Surge protection connector type 2 with series connection consisting of varistor and gas-filled spark gap for VAL-MS base element, thermal monitoring, visual fault warning. Design: 350 V AC

ZBN 18 CUS - Zack marker strip

0825059

<https://www.phoenixcontact.com/gb/products/0825059>



Zack marker strip, can be ordered: Strip, white, labeled according to customer specifications, mounting type: snap into tall marker groove, for terminal block width: 18 mm, lettering field size: 18 x 5 mm, Number of individual labels: 5

VAL-MS 350VF - Type 2 surge arrester

2856582

<https://www.phoenixcontact.com/gb/products/2856582>



B-STIFT - Marker pen

1051993

<https://www.phoenixcontact.com/gb/products/1051993>



Marker pen, for manual labeling of unprinted Zack strips, smear-proof and waterproof, line thickness 0.5 mm

SZK PZ2 VDE - Screwdriver

1206463

<https://www.phoenixcontact.com/gb/products/1206463>



Screwdriver, PZ crosshead, VDE insulated, size: PZ 2 x 100 mm, 2-component grip, with non-slip grip

VAL-MS 350VF - Type 2 surge arrester

2856582

<https://www.phoenixcontact.com/gb/products/2856582>



VAL-MS 350 VF ST - Type 2 surge protection plug

2856595

<https://www.phoenixcontact.com/gb/products/2856595>



Surge protection connector type 2 with series connection consisting of varistor and gas-filled spark gap for VAL-MS base element, thermal monitoring, visual fault warning. Design: 350 V AC

Phoenix Contact 2024 © - all rights reserved

<https://www.phoenixcontact.com>

PHOENIX CONTACT Ltd
Halesfield 13, Telford
Shropshire, TF7 4PG
01952 681700
info@phoenixcontact.co.uk