

12300100001

D985 |5| ZPL HX LCKNT/INS SP M10

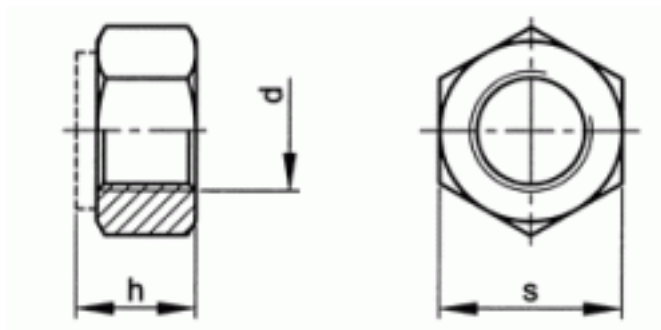

Brand	-
UBB Code	950355116175
UNSPSC Code	31161727
EAN Code	8715492576873
Driving features	hexagon
Thread	Metric thread
Class	≥ 5
Material	Steel
Surface treatment	Zinc plated



s	17
h	10
P	1,5
d	M10
Packaging (Piece)	200.0



Copyright Fabory Group